

Stahl-Umfassungszarge Typ TTUDS auf MBW oder LBW, aus 1.5 mm elektrolytisch verzinktem Stahlblech, Ecken auf Gehrung.

Kombinierbar mit Türen von 39-41mm Dicke:	
DB/40(.A)	Schallhemmend, o./m. Alu, 40mm
HGL/40	Holz/Glastür, 40mm
RS/40(.A)	Röhren-Vollspan, o./m. Alu, 40mm
VS/40(.A)	Vollspan, ohne/mit Alu, 40mm

gezeichnet: Bandseite = links

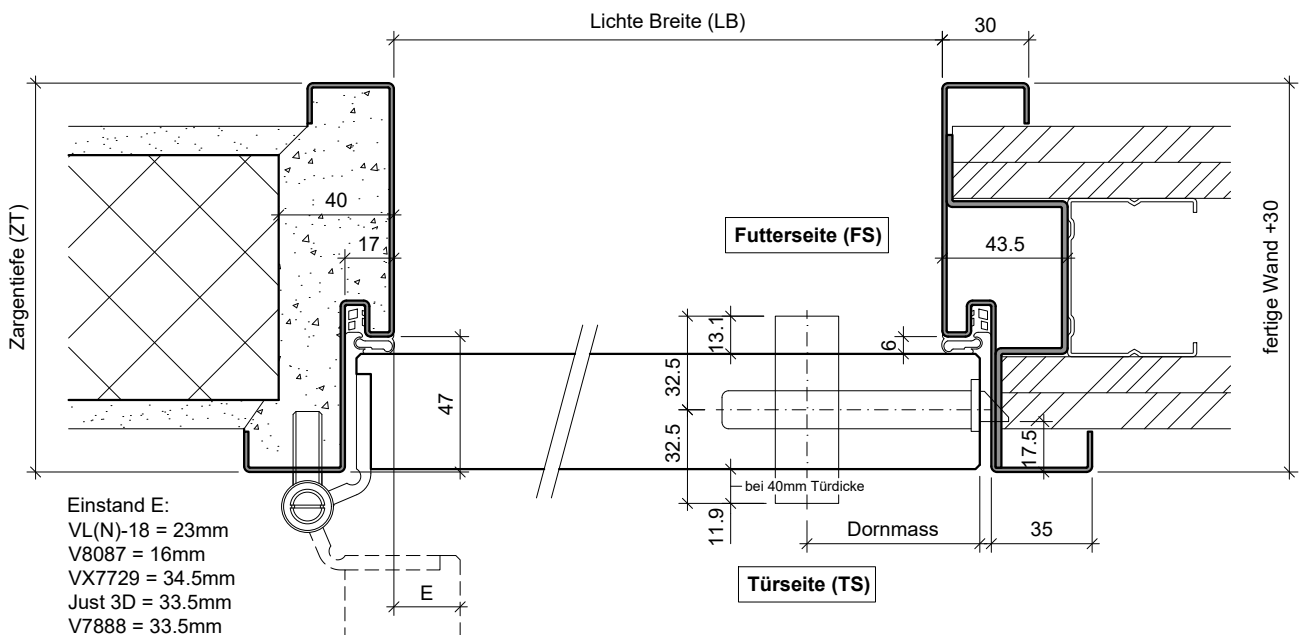
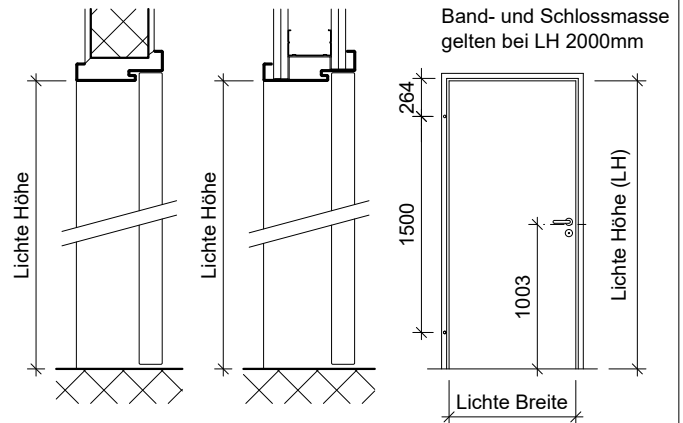

Einstand E:
 VL(N)-18 = 23mm
 V8087 = 16mm
 VX7729 = 34.5mm
 Just 3D = 33.5mm
 V7888 = 33.5mm

Typ: S
(Schwellenwinkel)

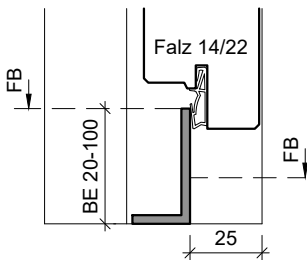

Typ: S
(Schwellenwinkel)

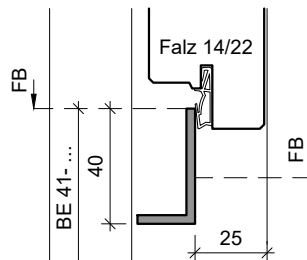

Typ: S+S
(Doppelschwelle)

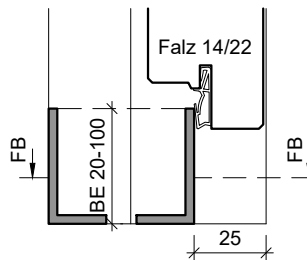

Typ: S+S
(Doppelschwelle)

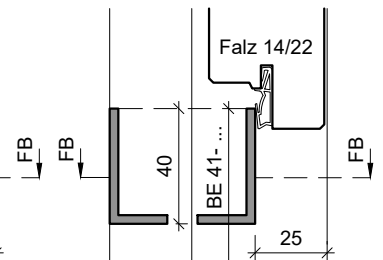

Typ: S (auf FS)
(Konterschwelle)

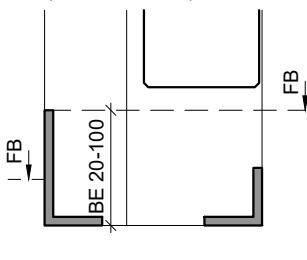

Typ: S (auf FS)
(Konterschwelle)

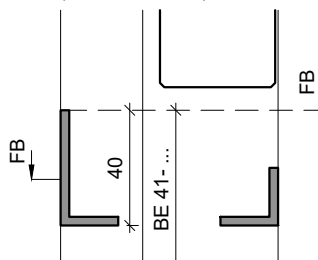

Typ: V
(Verbindungseisen)

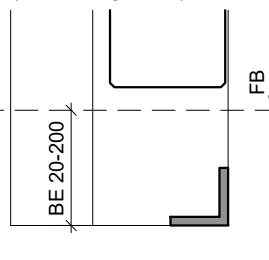

Typ: VP
(prov. Verbindungseisen)

