

Holzrahmen aus Hartholz Typ RD17-30,
 als Blend- oder Blockrahmen (gründiert oder lackiert)
 auf resp. zwischen MBW oder LBW montiert.

Kombinierbar mit Türen von 45-50mm Dicke:	
DB/45(.A)	Schallhemmend, o./m. Alu, 45mm
DB/49(.A)	Schallhemmend, o./m. Alu, 49mm
RS/45(.A)	Röhren-Vollspan, o./m. Alu, 45mm
RS/49(.A)	Röhren-Vollspan, o./m. Alu, 49mm
VS/45(.A)	Vollspan, ohne/mit Alu, 45mm
VS/49(.A)	Vollspan, ohne/mit Alu, 49mm
WD/45.A	Wärmed., mit Alu, 45mm, Ud 1.1

Weitere Schwellenprofile: siehe Zeichnung Nr. 10090+10383
 gezeichnet: Bandseite = links

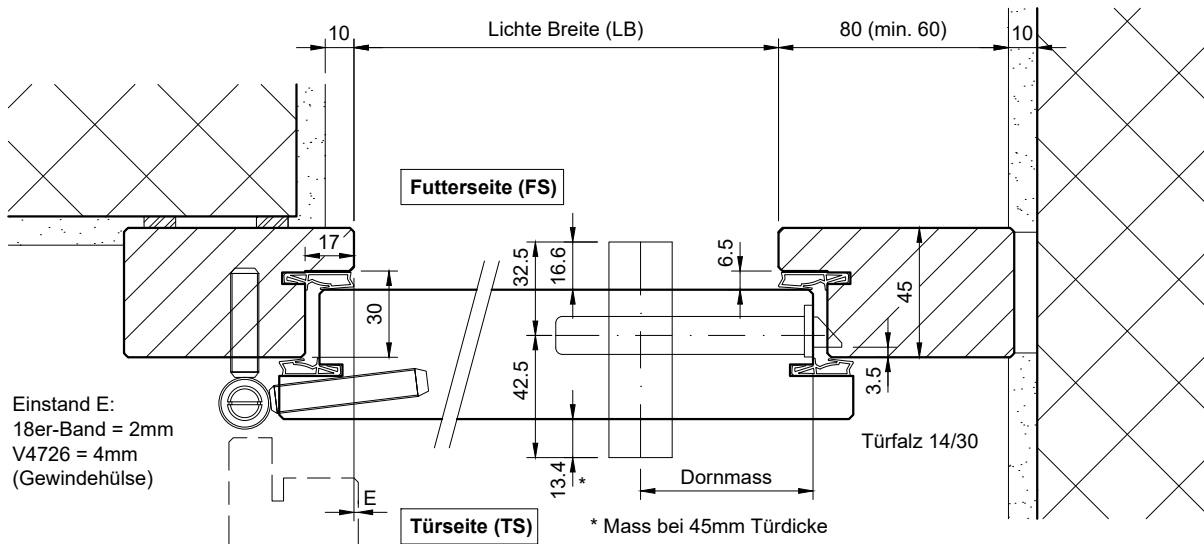
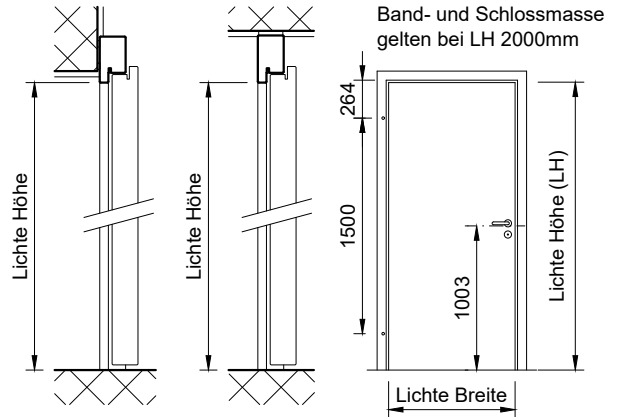

Einstand E:
 18er-Band = 2mm
 V4726 = 4mm
 (Gewindehülse)

