

Holzrahmen aus Hartholz Typ RDS17-43,  
 als Blend- oder Blockrahmen (gründiert oder lackiert)  
 auf resp. zwischen MBW oder LBW montiert.

Kombinierbar mit Türen von 48-51mm Dicke:	
DB/49(.A)	Schallhemmend, o./m. Alu, 49mm
RS/49(.A)	Röhren-Vollspan, o./m. Alu, 49mm
VS/49(.A)	Vollspan, ohne/mit Alu, 49mm

Weitere Schwellenprofile: siehe Zeichnung Nr. 10092

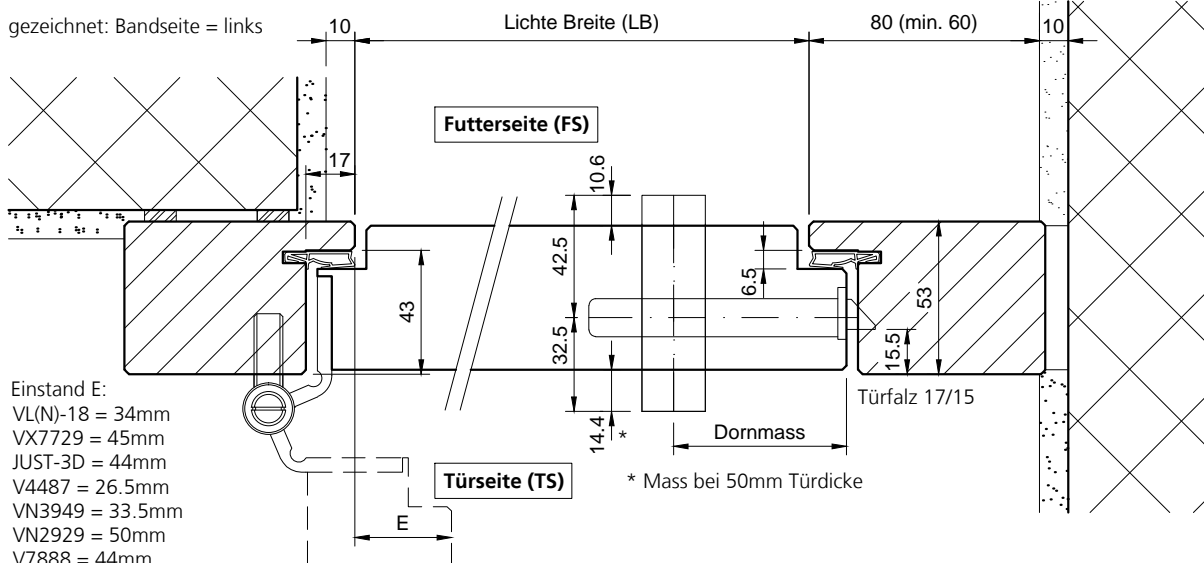
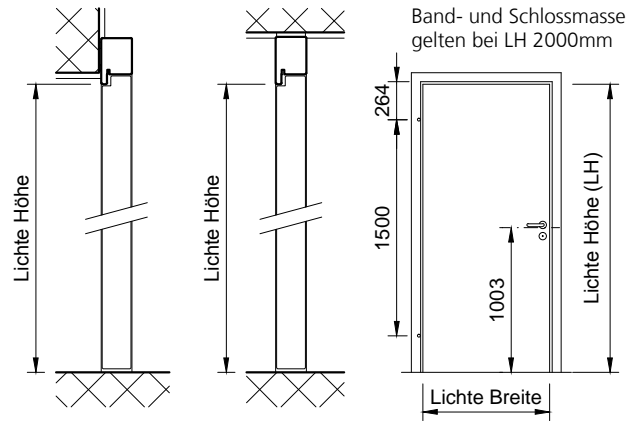

- Einstand E:  
 VL(N)-18 = 34mm  
 VX7729 = 45mm  
 JUST-3D = 44mm  
 V4487 = 26.5mm  
 VN3949 = 33.5mm  
 VN2929 = 50mm  
 V7888 = 44mm  
 VN2927 Compact Planum = 46mm  
 TECTUS-240N = 34mm (max. LB/LH beachten!)

