

Stahlzarge z.B. TTUDS, UDS, UDS58

Tür-Dicke	Falz GF	Wange SF	Nase	Z/K	M/K	Z/H	M/H
39-47	FD-14/30	W-14/24	3.5	21	12.5	-	-
48-52	FD-14/40	W-14/34	5.5	31	22.5	32	25.5

Kombination mit Planet-Senkdichtung siehe Zeichnung Nr. 10179

gezeichnet: Gehflügel = links

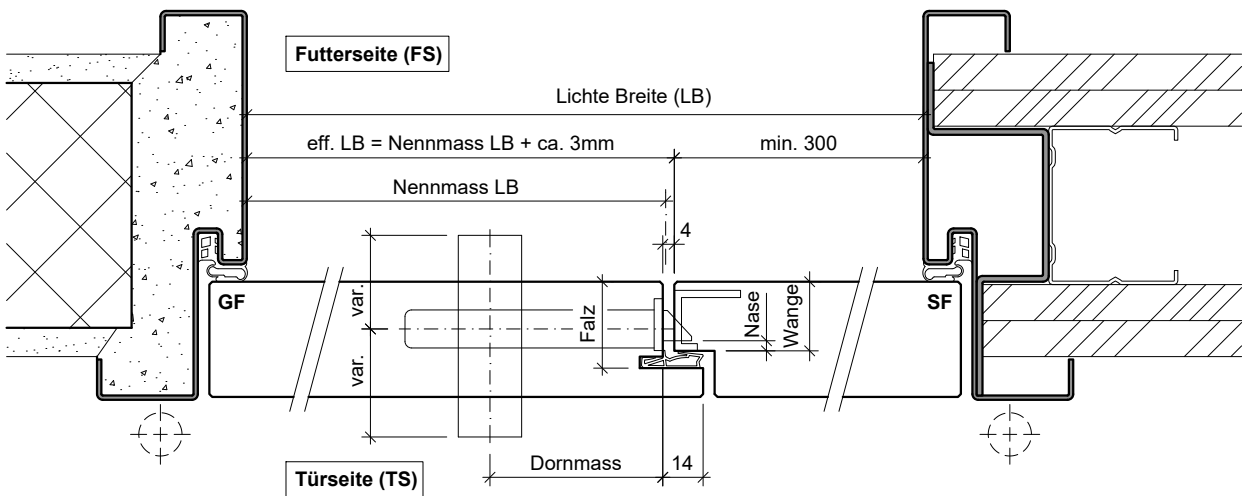
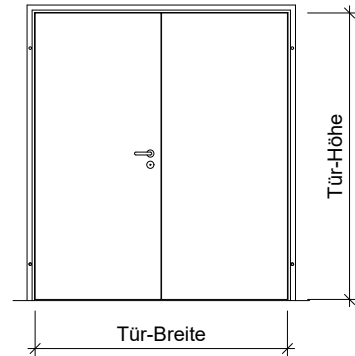

Bodenhülse 8.5mm
für Kantenriegel Ø7.5mm
Messing

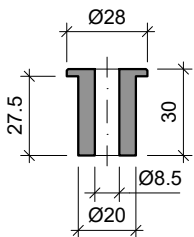

Bodenhülse 9mm
für Kantenriegel Ø7.5mm
Edelstahl
(für Zimmertüren, Parkett etc.)

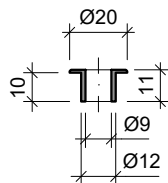

Bodenhülse 12mm
für Hebelkantenriegel 8/8mm
Messing

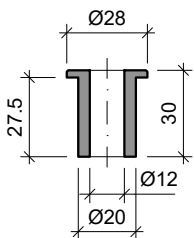

Bodenhülse 14.5mm
für aufges. Treibriegel 10/10mm
Messing

