

Holzrahmen z.B. RD17-30, RD17-33, RD17-40  
(Türtyp TT-TOP nicht 2-flügelig möglich)

Tür-Dicke	Falz GF	Wange SF	Nase	Z/K	M/K	Z/H	M/H
39-47	FD-14/30	W-14/24	3.5	21	12.5	-	-
48-52	FD-14/40	W-14/34	5.5	31	22.5	32	25.5
58-62	FD-14/50	W-14/44	5.5	37	28.5	37	30.5

Kombination mit Planet-Senkdichtung siehe Zeichnung Nr. 10179

gezeichnet: Gehflügel = links

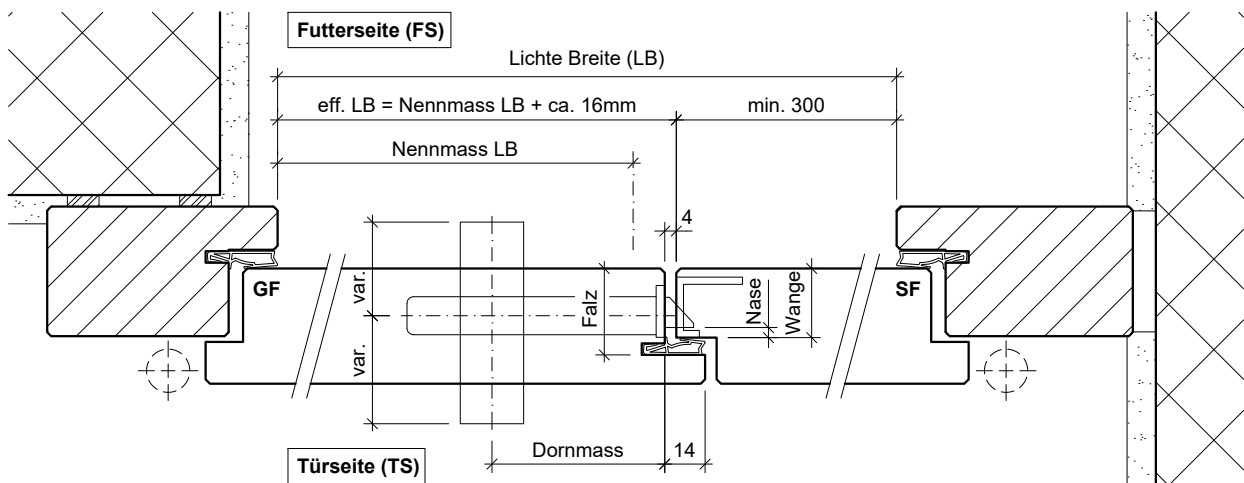
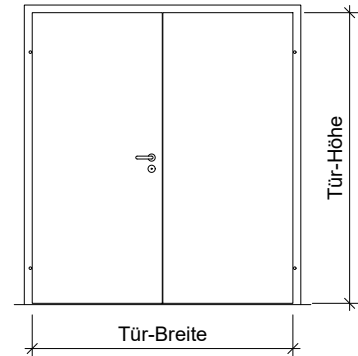

Bodenhülse 8.5mm  
für Kantenriegel Ø7.5mm  
Messing

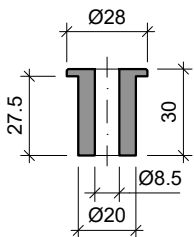

Bodenhülse 9mm  
für Kantenriegel Ø7.5mm  
Edelstahl  
(für Zimmertüren, Parkett etc.)

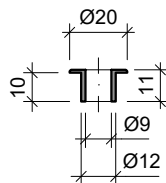

Bodenhülse 12mm  
für Hebelkantenriegel 8/8mm  
Messing

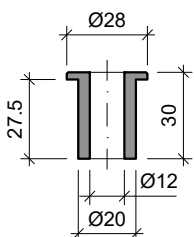

Bodenhülse 14.5mm  
für aufges. Treibriegel 10/10mm  
Messing

