

Stahlzarge TTUDS, Schwellenprofil ZSP22
KZA: CNS-SP22

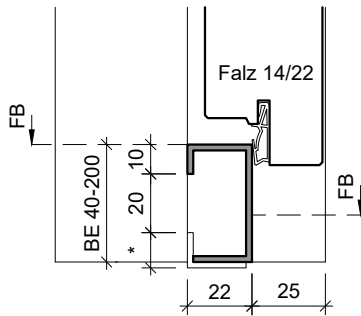

Stahlzarge TTUDS, Bodenverbindung VSP22
KZA: CNS-SP22

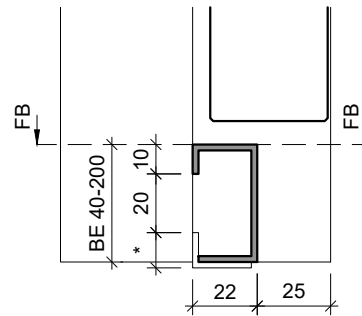

Stahlzarge UDS58, Schwellenprofil ZSP26
KZA: CNS-SP26

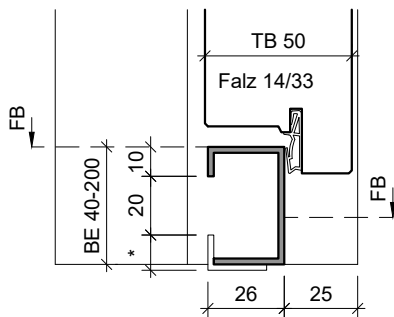

Stahlzarge UDS58, Bodenverbindung VSP26
KZA: CNS-SP26

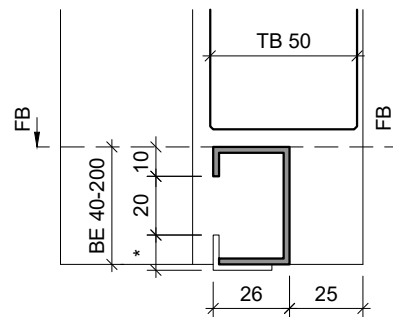

Stahlzarge UDS58, Schwellenprofil ZSP26
KZA: CNS-SP26

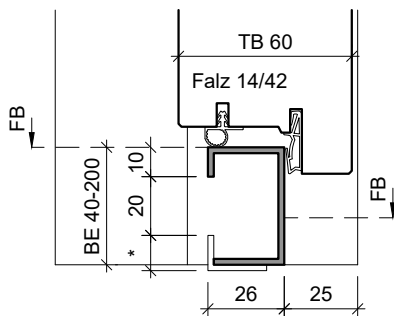

Stahlzarge UDS58, Bodenverbindung VSP26
KZA: CNS-SP26

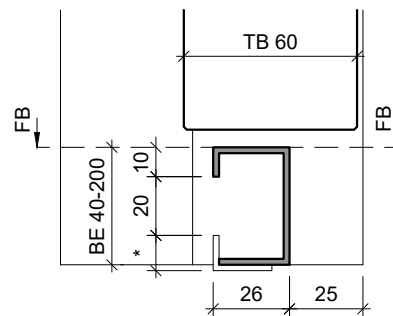

Stahlzarge UDS27/39, Schwellenprofil ZSP33
KZA: CNS-SP33

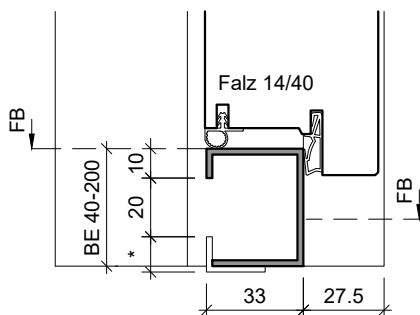

Stahlzarge UDS27/39, Bodenverbindung VSP33
KZA: CNS-SP33

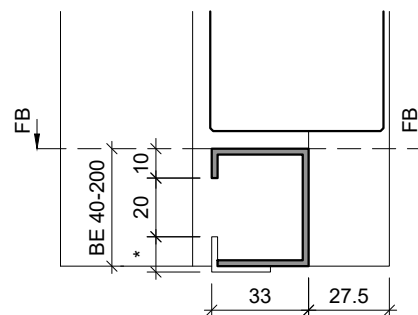

* Winkelhöhe variabel, abhängig von Bodeneinstand