

Holzrahmen RDS14-41

Tür-Dicke	Falz GF	Wange SF	Nase	Z/K	M/K	Z/H	M/H
49	FD-14/40	W-14/34	5.5	31	22.5	31	24.5

Kombination mit Planet-Senkdichtung: siehe Zeichnung Nr. 10389

gezeichnet: Gehflügel = links

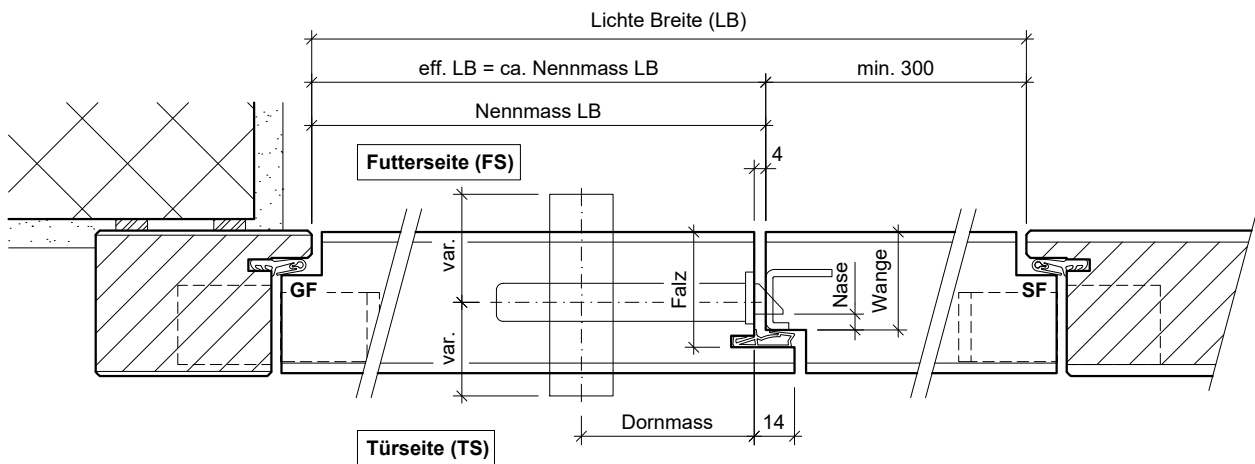
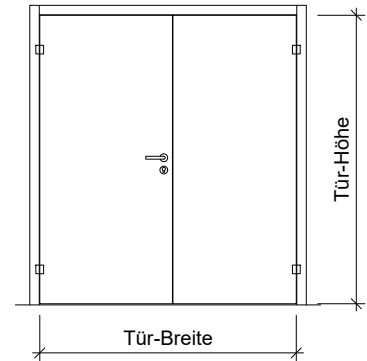

Bodenhülse 8.5mm
für Kantenriegel Ø7.5mm
Messing

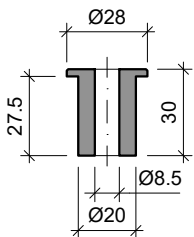

Bodenhülse 9mm
für Kantenriegel Ø7.5mm
Edelstahl
(für Zimmertüren, Parkett etc.)

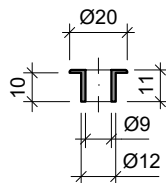

Bodenhülse 12mm
für Hebelkantenriegel 8/8mm
Messing

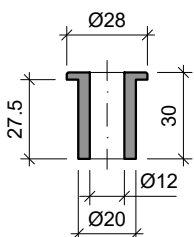

Bodenhülse 14.5mm
für aufges. Treibriegel 10/10mm
Messing

